

Hisense

Qingdao Hisense HVAC Equipment Co., Ltd.
Hisense Tower, Qingdao, China

<http://www.hisensehvac.com> export@hisensehitachi.com [HisenseHVACGlobal](#) [Hisense HVAC](#) [Hisense HVAC](#)

CE CB



HCAC-CA-HIMODVE1202207

★ Design and specifications are subject to change without notice. Pictures and diagrams are for reference only and are subject to change without notice.
All rights reserved by Qingdao Hisense HVAC Equipment Co., Ltd.

Hisense

Hi-Mod VE1 Series

DC Inverter Air-cooled Modular Chiller

Reimagine your solution



Hisense SINCE 1969

Hisense Group is a well-known large-scale electronic information industry group company. Based on technology and focusing on innovation-oriented culture, its scientific and efficient technological innovation system makes Hisense always be at the forefront of the counterparts. Hisense brand family has continued to grow with Toshiba, Gorenje and ASKO. Multi-brand operations will be defined according to Group's Strategy Management Department.

MANUFACTURING BASE

Qingdao Hisense HVAC Equipment Co., Ltd. is a wholly owned subsidiary of Qingdao Hisense Hitachi Air-conditioning Systems Co., Ltd., who is a joint-venture of Hisense and Hitachi (changed to Johnson Control Hitachi in 2015) and was established in 2003. It integrates technology development for commercial and residential CAC, product manufacturing, marketing and service as a whole.

With solid technical innovation strength, Hisense HVAC has participated in the formulation and revision of 50 national standards, industry standards and association standards, and has 1045 authorized patents in the field of CAC and heat pump products. Since 2008, 65 technologies have reached the advanced level through authorized certification. Now Hisense HVAC has become a leading CAC enterprise in China.

Note: The above data is valid before Dec. 31th, 2021.



266,000m²
Manufacturing Area



40+
Production Line



6,000,000 units/year
Production Capacity



16,700m²/70+
Laboratory





Hi-Mod VE1

CONTENTS

High Efficiency

03

High Reliability

08

High Flexibility

12

Specifications

15

Installation Instructions

19

High Efficiency

// Inverter EVI Compressor for High-efficiency Heating

A new generation of DC inverter EVI scroll compressor is adopted, which facilitates strong heating under low ambient temperature and improves the power and energy efficiency greatly. All products of Hi-Mod VE1 series adopt all inverter technology, that is, all compressors are high-performance DC EVI scroll compressors, and all fan motors use DC inverter motors, which brings an extraordinary experience to users.

Vapor injection technology

Lower discharge temperatures, increasing capacity and expanded operating envelop for enhanced performance.

Non-contact oil membrane

Oil film seals involute section of scroll set, reducing compression leakage for improved performance and lower sound.

Highly reliable bearings

Cylindrical bearing and aligning ball bearing, better reliability.

Efficient motor

Better performance at low and medium speeds, lower winding height and less copper loss; high efficiency in a wide speed range of 10-140 rpm.

High efficiency oil filter

Clean lubricating oil, efficient lubrication

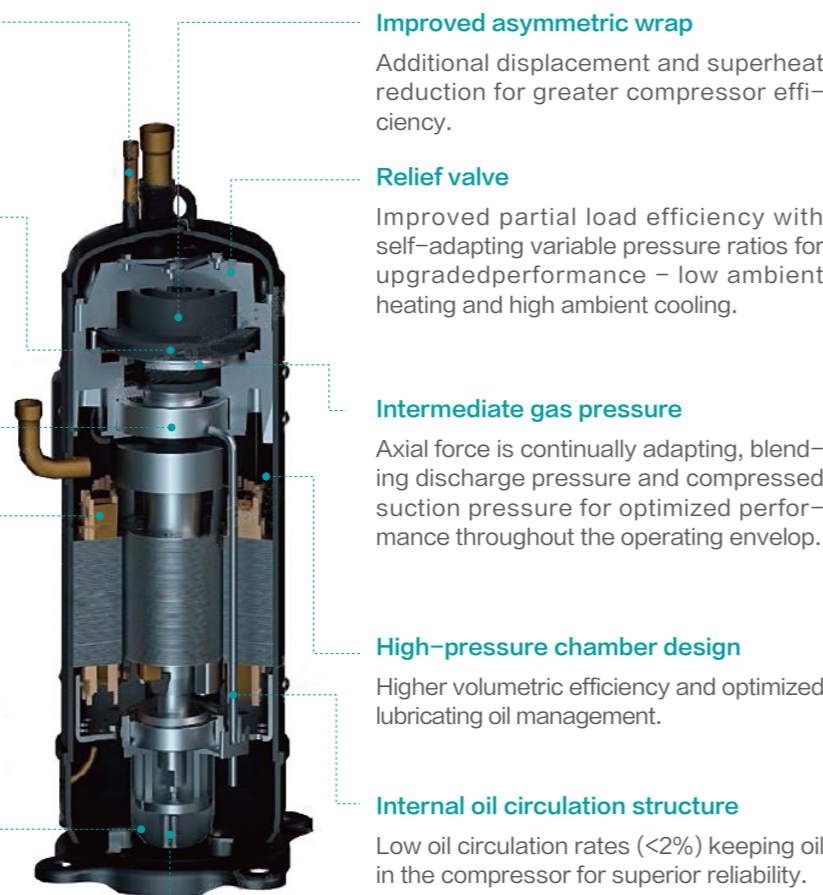

Improved asymmetric wrap

Additional displacement and superheat reduction for greater compressor efficiency.

Relief valve

Improved partial load efficiency with self-adapting variable pressure ratios for upgraded performance - low ambient heating and high ambient cooling.

Intermediate gas pressure

Axial force is continually adapting, blending discharge pressure and compressed suction pressure for optimized performance throughout the operating envelop.

High-pressure chamber design

Higher volumetric efficiency and optimized lubricating oil management.

Internal oil circulation structure

Low oil circulation rates (<2%) keeping oil in the compressor for superior reliability.

Positive displacement gear pump

Ensure necessary oil supplied at variable speed, improve product reliability.

// EVI Compressor Featured with Secondary Compression for Strong Heating Under Low Ambient Temperature

Thanks to the EVI secondary compression technology with economizer, the high-efficiency EVI compressor can largely improve EER and COP under rated cooling and heating conditions, and particularly optimize the heating cycle, which can significantly increase the heating capacity under low ambient temperature to realize more effective heating performance.

- Thanks to the EVI technology, the operation range of the system is wider than that of a conventional system. The operation range can be as low as -26°C.
- The highest outlet temperature is up to 55°C, meeting the requirements of heating terminals such as radiators.
- The outlet temperature can reach up to 55°C under the ambient temperature of -5°C, and up to 45°C under -25°C.



Economizer

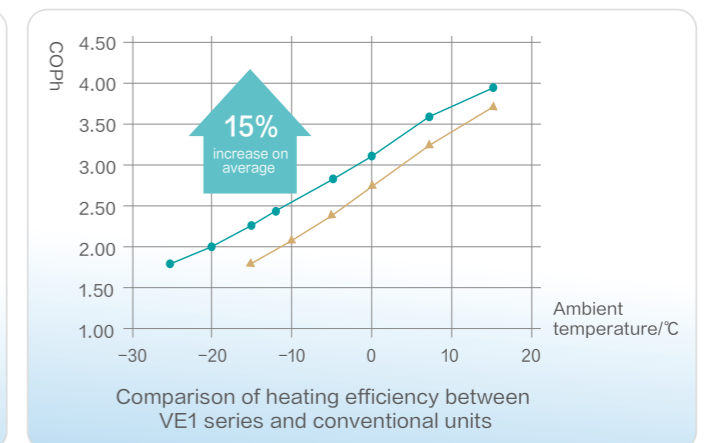
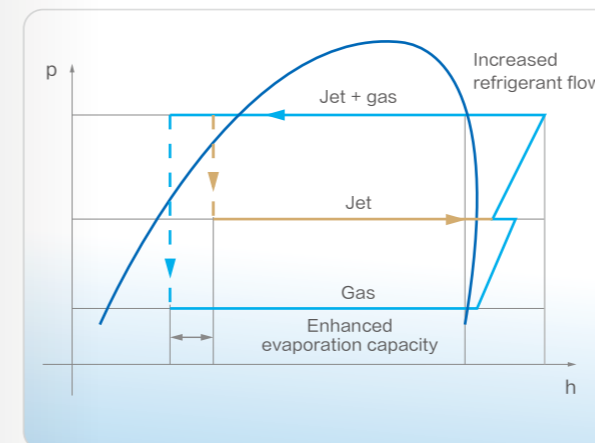

- Compared with the conventional fixed-speed system, the comprehensive energy efficiency of cooling performance is improved by 20%.

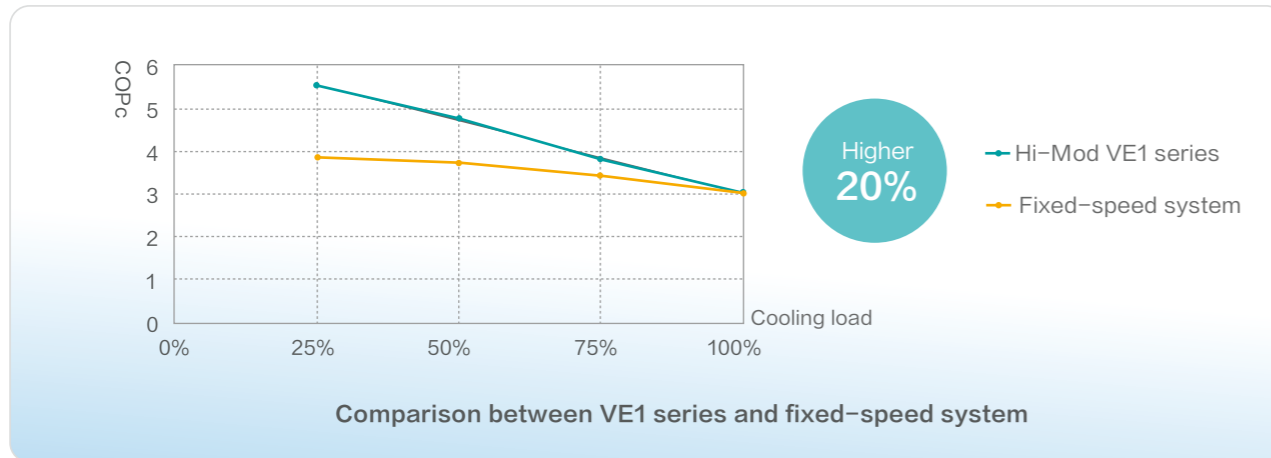

Stepless Fan-speed Control

The Hi-Mod VE1 series adopts DC variable speed fan motor, which can greatly reduce the power consumption. The fan speed is adjusted steplessly according to the ambient conditions and air conditioning load, which also matches with the stepless inverter technology of the compressor to get high-efficiency and reliable performance.

- The stability of discharge pressure and suction pressure of compressor is assured.
- The allocation of refrigerant is more stable, and the capacity output of indoor unit is assured.
- Response to the fluctuation of air-conditioning load quickly and accurately.

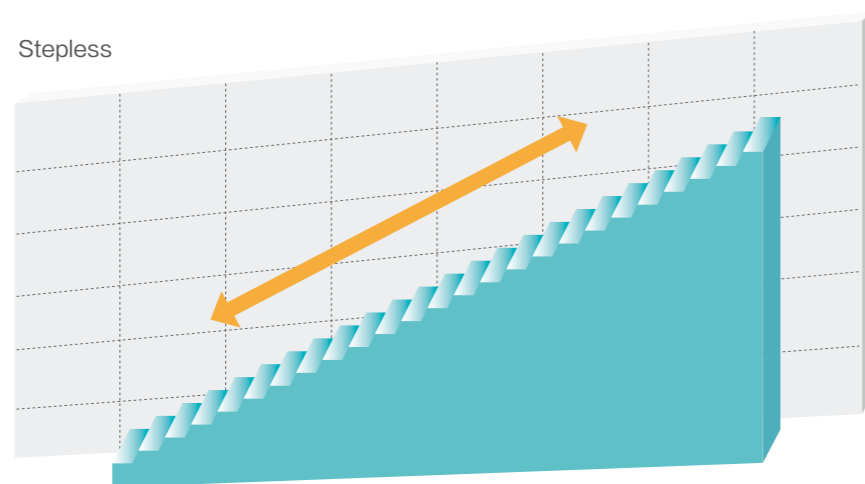

High-efficiency Heat Exchanger

- 7mm high-efficient internal-threaded tube, featured with a small volume and high heat-exchange coefficient.
- Adopt the window-type aluminum fins with a hydrophilic coating, which can slow down frost formation, facilitate the rapid removal of defrosted water, and improve heating performance.
- The multi-row and small-bore refrigerant piping design increases the heat exchange area and further optimizes the exchanger's efficiency.

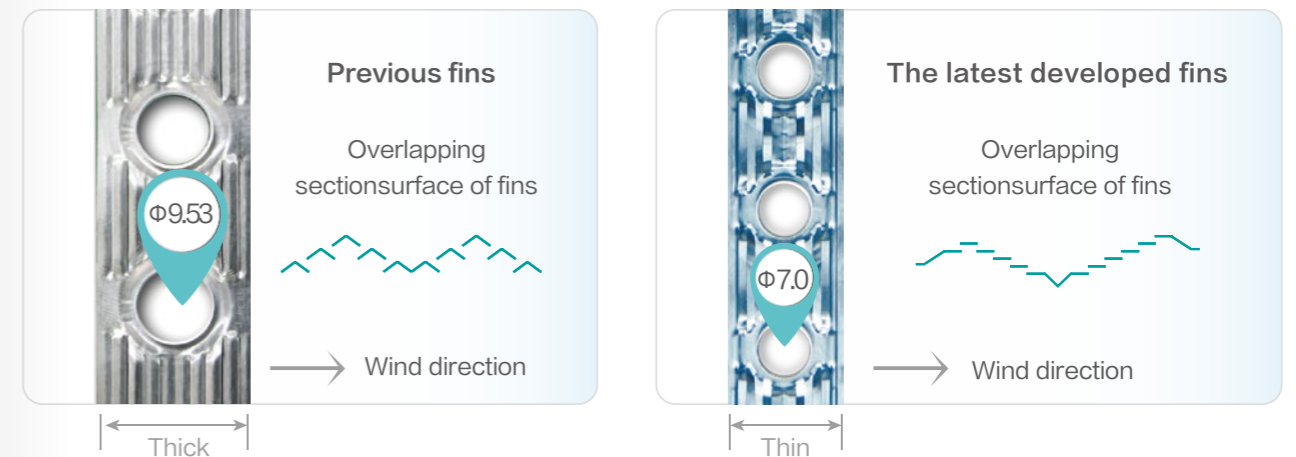
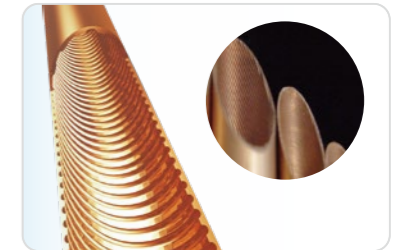

High-efficiency Plate Heat Exchanger

- The water side of the host adopts the high-efficiency stainless steel plate heat exchanger, featured with solid structure and high corrosion resistance.
- Be standard with a stainless steel water filter, with water resistance of less than 10kPa, ensuring stable and high-efficiency operation.

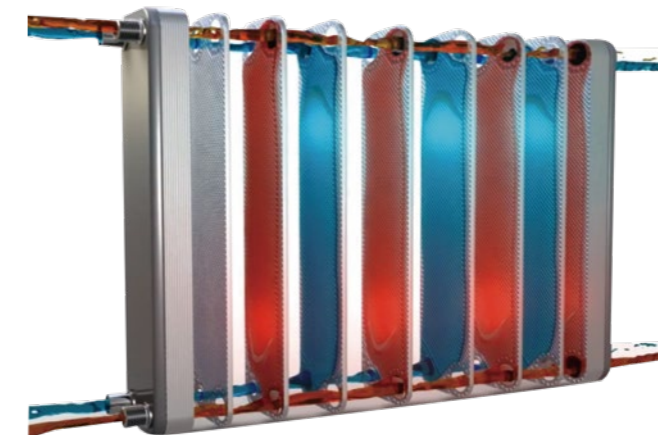

High Reliability

// Intelligent Defrosting

Continuous Heating during defrosting

- The heat exchanger is equipped with dual temperature sensors to accurately determine the frosting conditions, and defrost promptly based on the ambient temperature, evaporation temperature, and operational time.
- The defrosting time is automatically adjusted to reduce ineffective defrosting, improving heating efficiency.
- When the modules are combined, the number of defrost systems at the same time can be set from 1 to 16.
- Under standard conditions, the longest defrosting interval defaults to 2 hours, which can be adjusted.
- The single module is designed as a double fluorine single water system, the water side heat exchanger is shared, and the air side heat exchanger is separated, and the unit load is controlled by the total inlet and outlet water temperature.
- The dual fan systems are completely separated to operate independently for alternate defrosting.

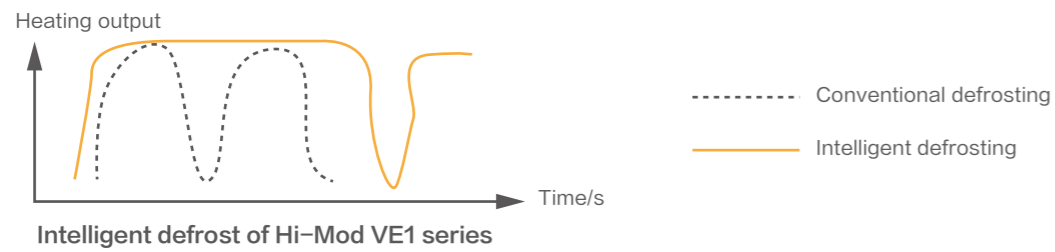

Heating

Defrosting

Heating

// Multiple Protections Ensuring Safety and Stability

- The system is equipped with multiple safety functions as related to compressor, fan motor, water flow, high or low pressure of the refrigeration system, water temperature, power supply, current, communication, etc., to ensure the safe and steady operation.
- Standard water switch and multiple anti-freezing protection procedures provide comprehensive anti-interruption and anti-freezing protection for the system.
- To prevent the water system from freezing during standby, the water pump can be started automatically by the anti-freezing control depending on the ambient temperature and the inlet water and outlet water temperature to eliminate potential risks.
- There is a minimum operation time for the compressor, to prevent the compressor from damage due to frequent starts and stops.



IP55 DC brushless permanent magnet motor

- Dustproof and waterproof grade IP55, safe and worry-free for outdoor applications
- Insulation class: F class
- The fan motor obtains the CE certification

High-quality Flow switch

The water flow switch can monitor the flow rate of water in real time, and when the water flow is abnormal, it can be fed back to the host in real time to ensure the stability and reliability of the host unit.

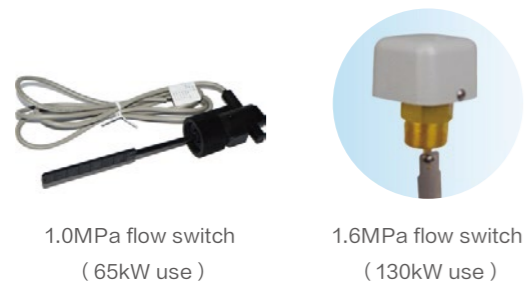

Lubricant Oil Management

- Equipped with high-efficiency external oil separator, the oil separation efficiency is as high as 98%, which effectively reduces the oil circulation in the system (<2%) and improves the energy efficiency of the unit.
- The compressor has a built-in oil filter to ensure that the lubricating oil of the compressor is clean and well lubricated throughout its life cycle.
- The compressor has a built-in positive displacement gear oil pump, which can actively supply oil at all times at each speed, ensuring worry-free lubrication.

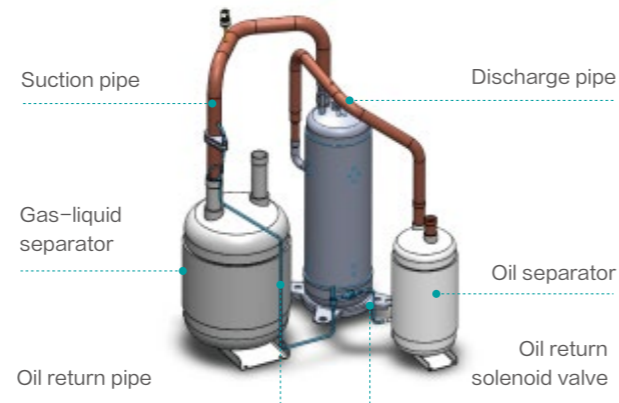

Noise Reduction Design

- The compressor is equipped with a fully enclosed sound insulation box as standard configuration, which effectively reduces the running noise of the compressor and makes the unit run more quietly.
- The sound insulation design adopts galvanized steel sheet combined with 20mm thick sound-absorbing cotton, which can reduce the operating noise of the compressor by 3-4dB(A).
- Low-noise fan motor and tooth-shaped noise reduction fan blade are applied in the unit. Compared with ordinary fans, the noise is reduced by 5dB(A), the noise of the Model 65 unit's fan is as low as 63dB(A), and 67dB(A) for that of the Model 130 unit.

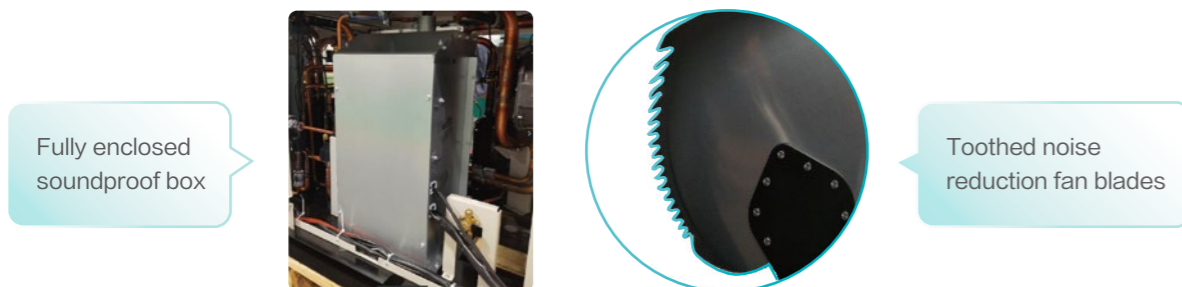

Intelligent Energy Regulation Technology

Stepless Inverter intelligent energy regulation

The capacity output of the system can be controlled steplessly by 10%~100% for accurate and intelligent load-based output regulation.

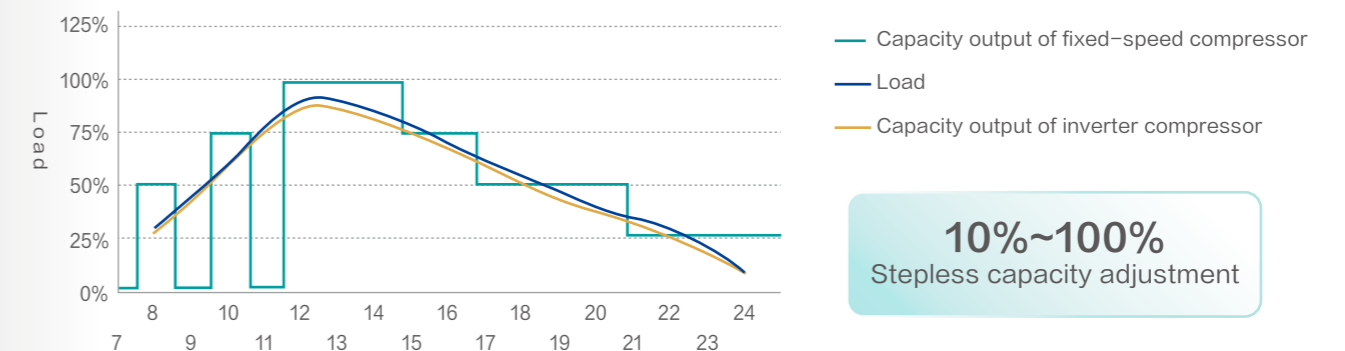

Intelligent Energy Regulation for Multiple modules

- The fixed-speed system carries out load control by regulating the number of compressors started and stopped. The outlet water temperature fluctuates dramatically, and the compressors operate at full load with low COP.
- The inverter system carries out load control by regulating the frequency of the compressor. In case of multiple modules, each system can automatically regulate the frequency. Thus, the outlet water temperature fluctuates slightly, and the COP can be increased by 15%~20%.



// Dual Systems Operating Independently

- The condensers and fans of the two systems are completely separated and operate independently without interfering with each other.
- The dual systems are standby for each other, with high reliability.
- When a system is operating, the fan of the other system can stop to reduce power consumption and realize high efficiency under partial load.



// Smart Rotative Operation of Compressors

Operation duties are smartly balanced between modulars to prevent overwork of individual unit and hence extend the overall operating life of the overall system.

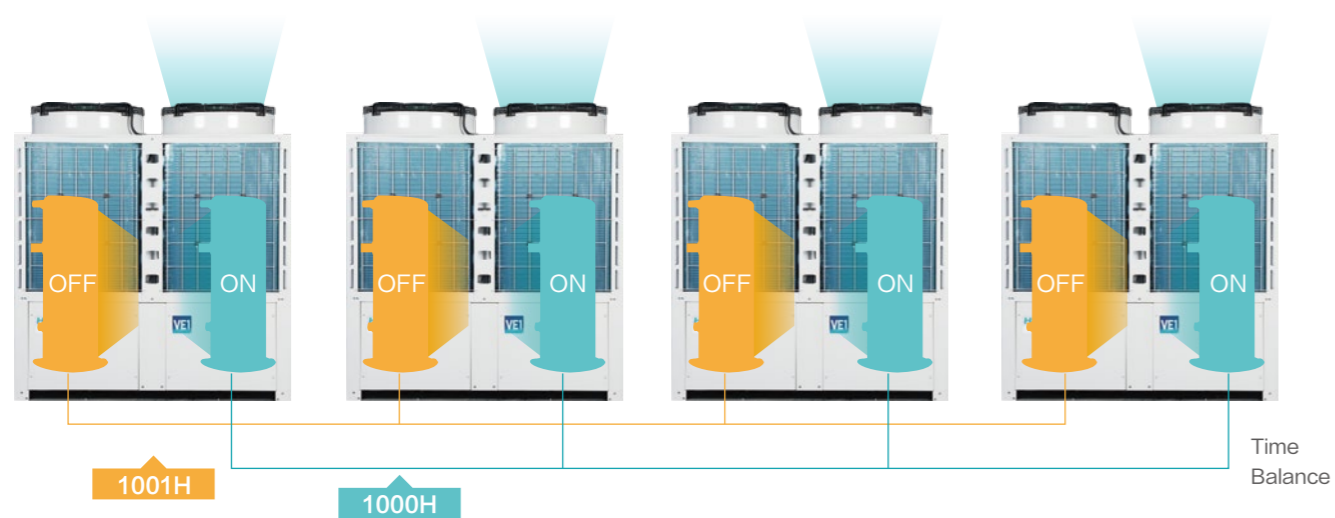

// Wide Operation Range and Wide Applications

Extended operation range creates wider application potential.

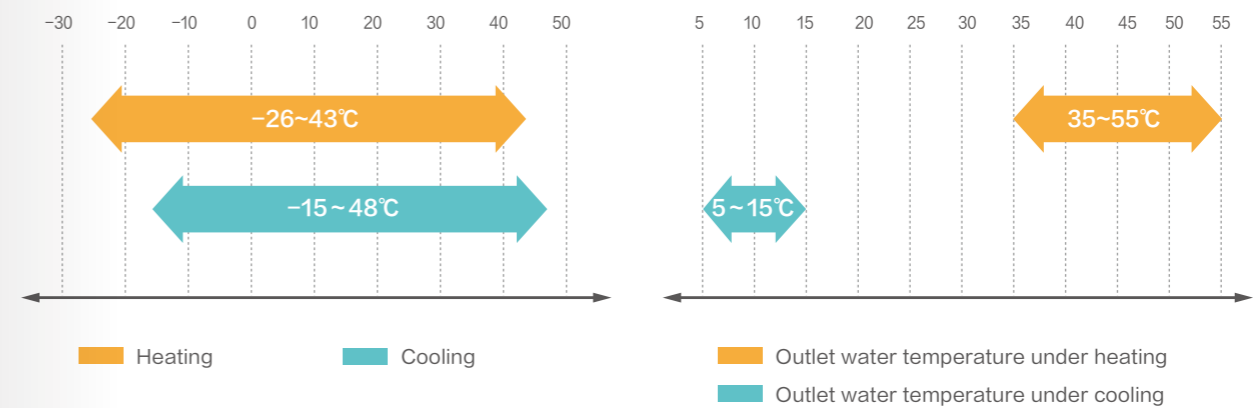

Hi-Mod VE1 series is featured with a wide temperature range of hot water and satisfies the hot water requirements of various heating terminals such as the old-fashioned cast-iron radiators, new-style copper-aluminum composite radiators, fan coils and floor heating and so on. It's widely used in data centers, electronic workshops, the medicine industry, the chemical industry and other process cooling occasions. It can also meet the application requirements of annual heat demand such as breeding and flowers.



// Compact Design, Occupying Small Area

The system is of a highly integrated structure that can reduce its volume and floor area significantly, facilitate its installation and transportation, and greatly reduce installation space and cost.

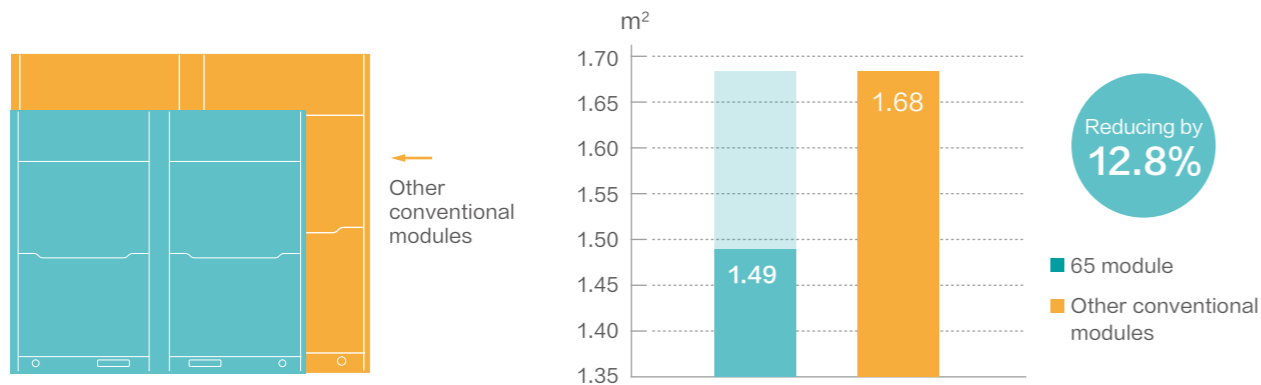

The 65 unit only covers a floor area of 1.49m²

Diagram of Floor Area Comparison

// Module Design, More Convenient for Installation and Transportation

- The main and sub units are designed without difference, and any unit can be set as the main unit, which makes the combination and installation more convenient.
- Free combination of different specifications of the same series is possible. A water system can be combined in parallel with 16 units at most to realize free combination within a cooling capacity of 65kW-2080kW.
- The direction of the outlet water pipes is unified, which facilitates transportation, installation, and commissioning.



// Wired Controller

- Support 7-day timer.
- It is compatible with the Modbus protocol, with RS485 interface, which can access to the BMS.
- Three levels of users management, user level, serviceman level and factory level.
- Max. 16 modules can be controlled.



HSXE-FA01M

// Connected to BMS

RS-485 signal interface is built in the controller, through which the unit can be connected to BMS. The interconnection of centralized control system realizes the networking group control and remote control.

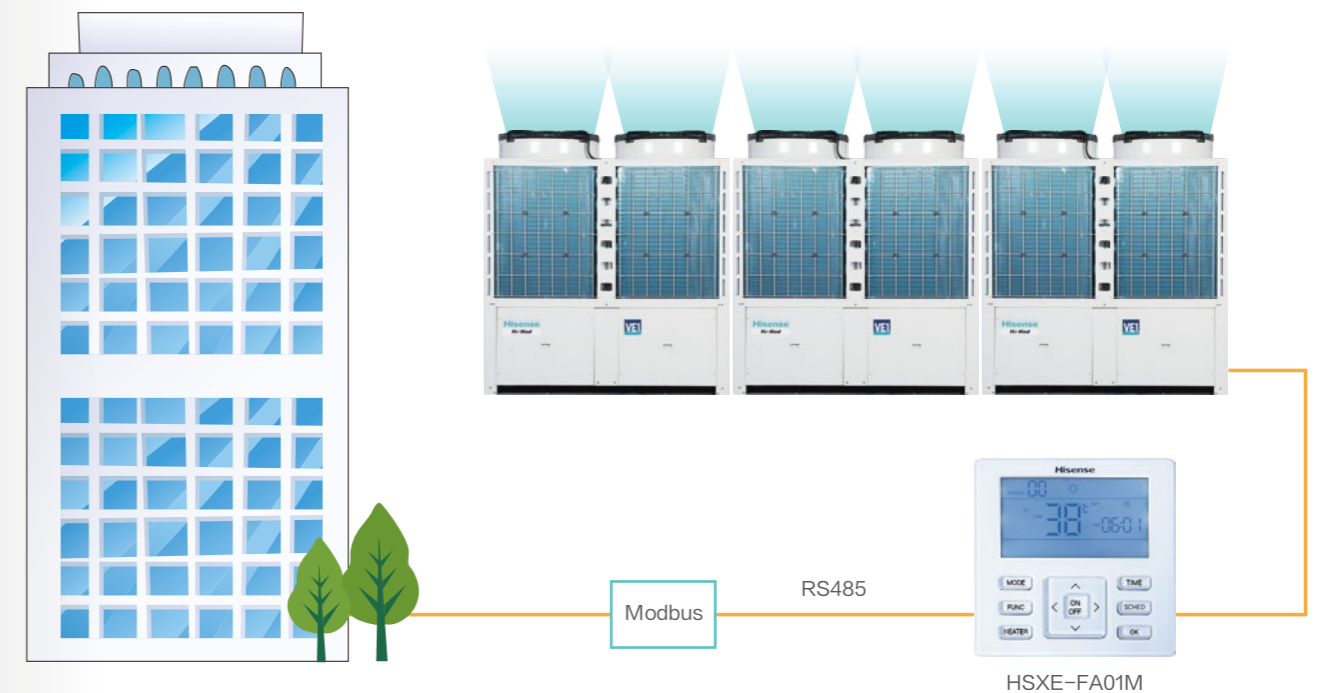

Specifications

// Nomenclature

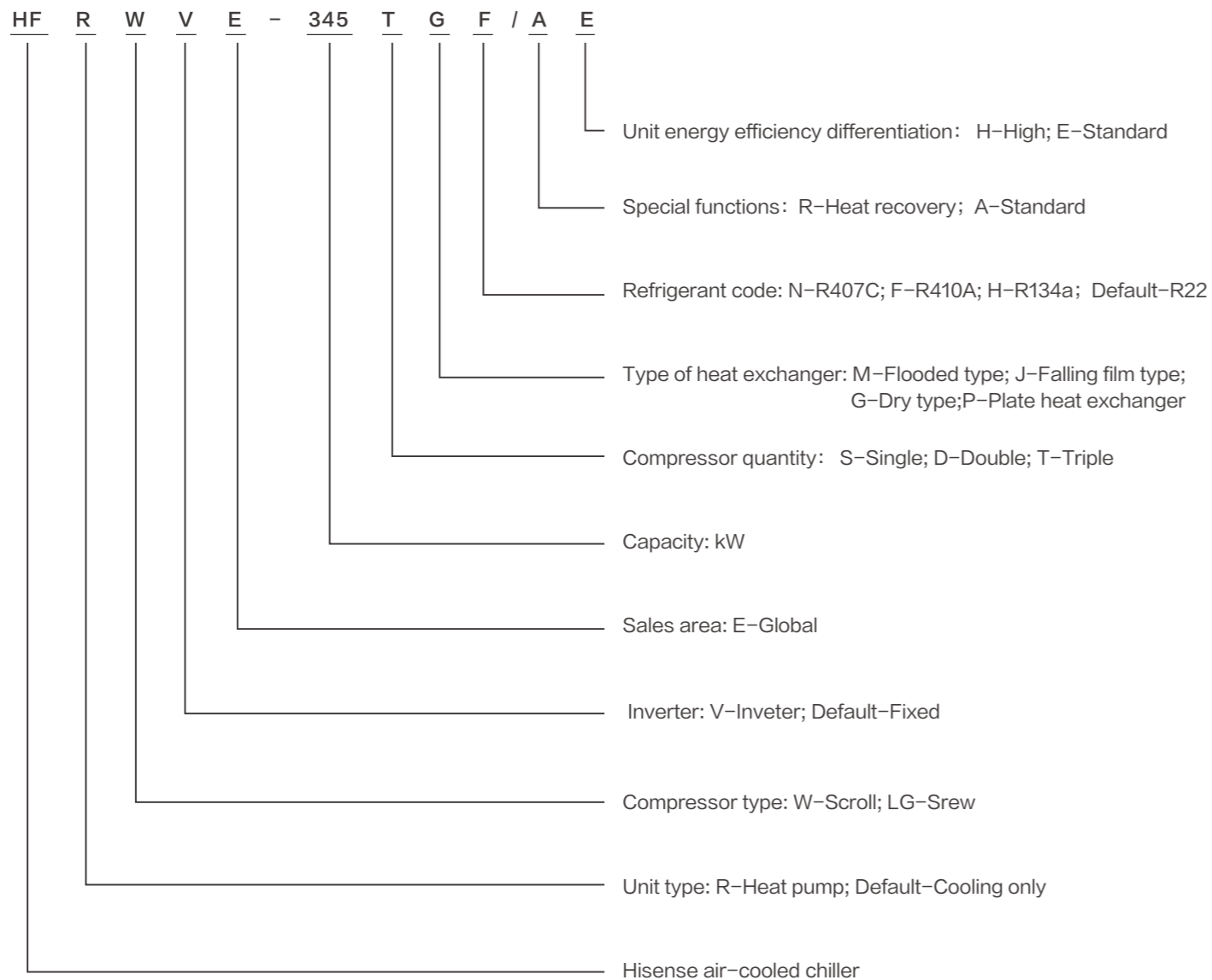

// Specification

Model		HFRWVE-65SPF/AE	HFRWVE-130DPF/AE	
Cooling Capacity	kW	63	126	
Heating Capacity	kW	68	136	
Cooling Power Input	kW	22.1	43.4	
Heating Power Input	kW	22.4	44.6	
Max. Power Input	kW	26.5	53	
Cooling Current	A	36	72	
Heating Current	A	37	74	
Max. Current	A	48	96	
COPc/COPh	-	2.85/3.04	2.9/3.05	
SEER	-	4.71	4.61	
SCOP(45°C Water Outlet)	-	2.87	2.91	
Capacity Regulation of Single Unit	-	Inverter stepless		
Power Supply	-	AC 3 φ , 380~415V/50Hz		
Rated Water Flow	m³/h	10.8	21.7	
Water Resistance(without Filter)	kPa	35	35	
Water Resistance(with Filter)	kPa	45	45	
Pipe Diameter(Inlet/Outlet)	-	G2-1/2"external thread		
Max.Pressure Bearing of Water Side HEX	MPa	1.0		
Operation Type	-	Automatic operation controlled by microcomputer		
Compressor Type	-	DC inverter scroll compressor		
Compressor Quantity	set	1	2	
Fan	Type	DC inverter axial low-noise blade		
	Total Volume	m³/h	24400	43000
	Quantity	set	2	2
Refrigerant	Type	R410a		
	Total Charge	kg	15.5	2×14.0
External Dimensions	L×W×H	mm	1950×765×1725	2190×1100×2360
Package Dimensions	L×W×H	mm	2030×840×1860	2250×1160×2485
Weight	Unit Weight	kg	490	910
	Gross Weight	kg	520	940
	Operation Weight	kg	510	930
Ambient Temperature	Cooling	°C	-15~48	
	Heating	°C	-26~43	
Outlet Water Temperature	Cooling	°C	5~15	
	Heating	°C	35~55	

Notes: 1.Cooling capacity and input power (cooling) are measured at rated water flow, outlet water temperature of 7°C, outdoor ambient dry bulb temperature of 35°C; Heating capacity and input power (heating) are measured at rated water flow, outlet water temperature of 45°C, outdoor ambient dry bulb temperature of 7°C/wet bulb temperature of 6°C.
 2.It is forbidden to run in heating mode when ambient temperature is below -26°C.
 3.The specifications and parameters of this product are subject to change due to product improvement without prior notice.
 4.The above modules can be used in the manner of combination, and max. 16 modules can be combined.

// Capacity Correction Table

HFRWVE-65SPF/AE

Unit: kW

Ambient Temp.(°C)	Cooling Outlet Water Temp.(°C)											
	5		7		9		11		13		15	
	CAP	PWR	CAP	PWR	CAP	PWR	CAP	PWR	CAP	PWR	CAP	PWR
-15	76.3	16.82	79.8	17.04	84.4	17.20	88.6	17.32	93.1	17.43	97.7	17.54
-7	74.9	16.99	78.5	17.18	83.2	17.36	87.7	17.47	92.1	17.61	96.6	17.73
0	73.6	17.14	77.4	17.31	82.1	17.50	86.8	17.61	91.3	17.78	95.7	17.89
10	71.8	17.35	75.9	17.49	80.5	17.70	85.5	17.82	90.1	18.01	94.3	18.13
20	69.8	17.76	73.9	17.88	78.5	18.11	83.4	18.22	88.2	18.45	92.1	18.57
25	66.5	18.99	70.6	19.11	75.0	19.34	80.0	19.57	84.3	19.68	88.2	19.91
30	63.0	20.49	66.8	20.72	71.0	20.95	75.7	21.18	79.9	21.29	83.5	21.52
35	59.4	21.87	63.0	22.10	67.0	22.33	71.3	22.56	75.3	22.79	78.8	23.02
40	54.7	23.60	58.0	23.83	61.6	24.06	65.6	24.40	69.2	24.63	72.5	24.86
45	49.9	25.09	52.9	25.32	56.2	25.55	60.0	25.90	63.3	26.13	66.2	26.36
48	42.4	23.41	44.9	23.52	47.6	23.72	50.9	24.14	53.7	24.34	56.2	24.55

Ambient Temp.(°C)	Heating Outlet Water Temp.(°C)									
	35.0		40.0		45.0		50.0		55.0	
	CAP	PWR	CAP	PWR	CAP	PWR	CAP	PWR	CAP	PWR
-26	31.2	18.31	30.3	19.69	28.7	21.33	-	-	-	-
-20	37.8	18.49	36.8	19.88	35.1	21.49	-	-	-	-
-12	46.5	18.75	45.4	20.19	43.0	21.78	41.0	23.44	-	-
-6	53.6	18.92	51.4	20.40	50.3	22.00	48.0	23.65	-	-
0	60.9	19.12	60.0	20.68	59.4	22.19	56.7	23.85	53.6	25.59
7	70.6	19.31	69.2	20.90	68.0	22.40	64.9	24.07	62.0	25.82
15	80.1	19.54	78.1	21.16	76.2	22.76	72.7	24.35	69.7	26.13
25	91.1	19.86	89.0	21.49	85.3	23.13	81.4	24.69	78.0	26.49
35	102.6	20.17	98.6	21.82	95.5	23.51	91.1	25.03	87.3	26.85
43	110.1	20.43	106.6	22.09	104.1	23.81	99.4	25.30	95.2	27.14

HFRWVE-130DPF/AE

Unit: kW

Ambient Temp.(°C)	Cooling Outlet Water Temp./°C											
	5		7		9		11		13		15	
	CAP	PWR	CAP	PWR	CAP	PWR	CAP	PWR	CAP	PWR	CAP	PWR
-15	152.5	33.12	159.6	33.54	168.8	33.86	177.3	34.09	186.2	34.31	195.5	34.53
-7	149.7	33.45	157.1	33.82	166.4	34.18	175.3	34.40	184.2	34.67	193.2	34.89
0	147.2	33.74	154.9	34.07	164.2	34.45	173.5	34.67	182.5	35.00	191.3	35.22
10	143.7	34.15	151.8	34.43	161.1	34.85	171.0	35.07	180.1	35.46	188.6	35.68
20	139.6	34.96	147.7	35.19	157.0	35.64	166.7	35.87	176.4	36.32	184.2	36.55
25	133.0	37.39	141.1	37.61	150.0	38.07	159.9	38.52	168.6	38.75	176.4	39.20
30	126.0	40.33	133.6	40.78	142.1	41.24	151.4	41.69	159.7	41.92	166.9	42.37
35	118.8	43.05	126.0	43.40	133.9	43.96	142.7	44.41	150.6	44.86	157.6	45.32
40	109.3	46.45	115.9	46.90	123.3	47.36	131.2	48.04	138.4	48.49	145.0	48.94
45	99.8	49.39	105.8	49.85	112.4	50.30	120.0	50.98	126.6	51.43	132.4	51.89
48	84.8	46.09	89.8	46.29	95.3	46.70	101.9	47.51	107.5	47.92	112.4	48.33

Ambient Temp.(°C)	Heating Outlet Water Temp.(°C)									
	35.0		40.0		45.0		50.0		55.0	
	CAP	PWR	CAP	PWR	CAP	PWR	CAP	PWR	CAP	PWR
-26	62.4	36.46	60.6	39.20	58.3	42.46	-	-	-	-
-20	75.6	36.82	73.6	39.58	71.1	42.78	-	-	-	-
-12	93.0	37.33	90.7	40.21	87.4	43.36	81.9	46.66	-	-
-6	107.2	37.67	102.8	40.62	100.6	43.81	96.0	47.08	-	-
0	121.8	38.07	120.1	41.17	118.9	44.17	113.4	47.48	107.1	50.95
7	141.2	38.45	138.3	41.62	136.0	44.60	129.8	47.92	124.1	51.41
15	160.3	38.91	156.3	42.14	152.3	45.32	145.4	48.49	139.3	52.03
25	182.1	39.54	178.0	42.79	170.6	46.06	162.8	49.16	156.0	52.74
35	205.2	40.16	197.1	43.45	190.9	46.80	182.2	49.83	174.6	53.46
43	220.2	40.67	213.2	43.99	208.3	47.40	198.7	50.37	190.5	54.04

Installation Instructions

// Dimensions

HFRWVE-65SPF/AE

unit: mm

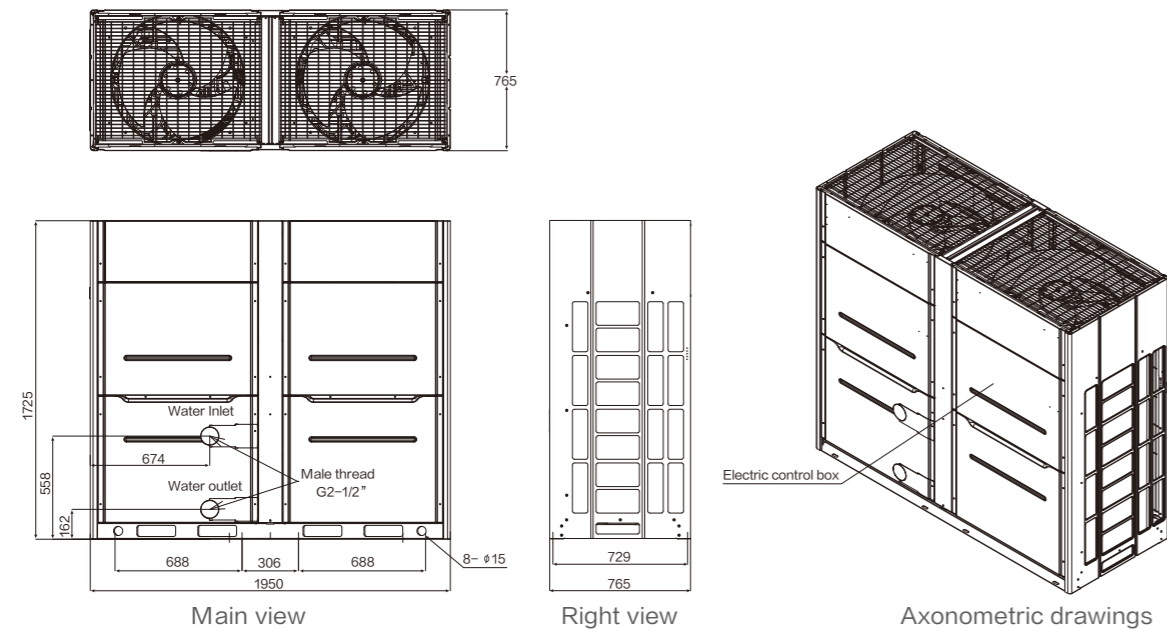

HFRWVE-130DPF/AE

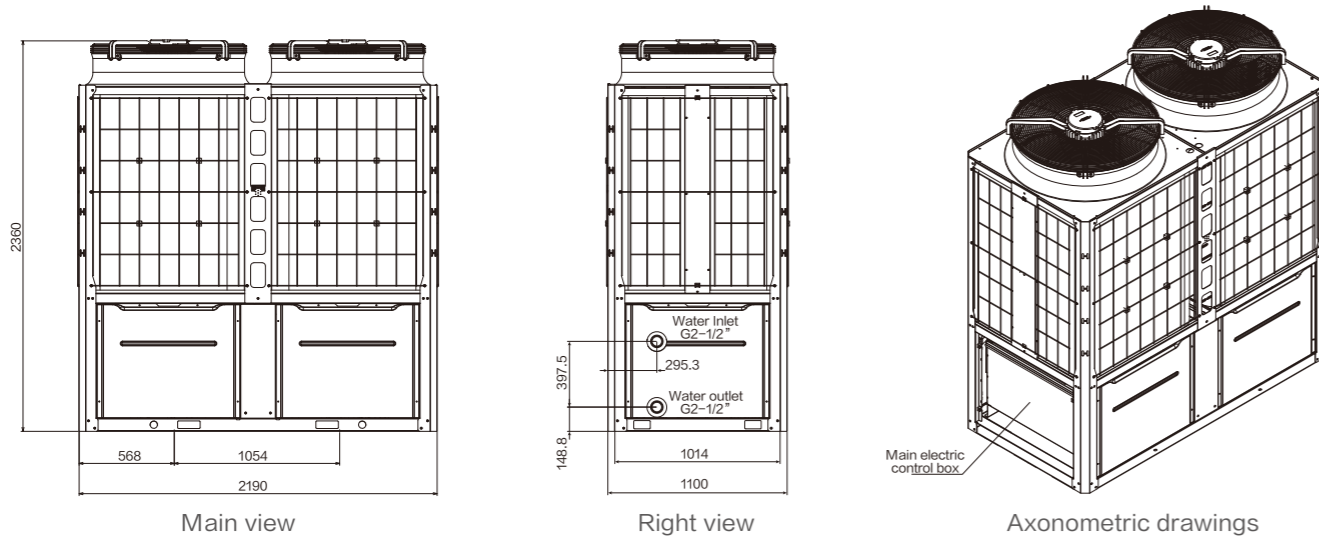

// Foundation Diagram

The modular air-cooled chiller must be installed and fixed on a solid foundation with anchor bolts. In order to reduce vibration and noise of the unit, rubber damping pad or absorbers must be used during installation. Due to the small weight of the unit, rubber pad with thickness of not less than 20mm can usually achieve good vibration absorbing effect. If the unit is installed on the ground, the foundation may be made of section steel or concrete. If the unit is installed on the skirt building, roof and other places that are sensitive to vibration, in order to prevent the vibration of the unit transferring along the building structure from affecting the living comfort, the foundation shall be made of concrete, of which the performance of vibration isolation and noise reduction is obviously better than that of section steel. Unit foundation diagram is as follows:

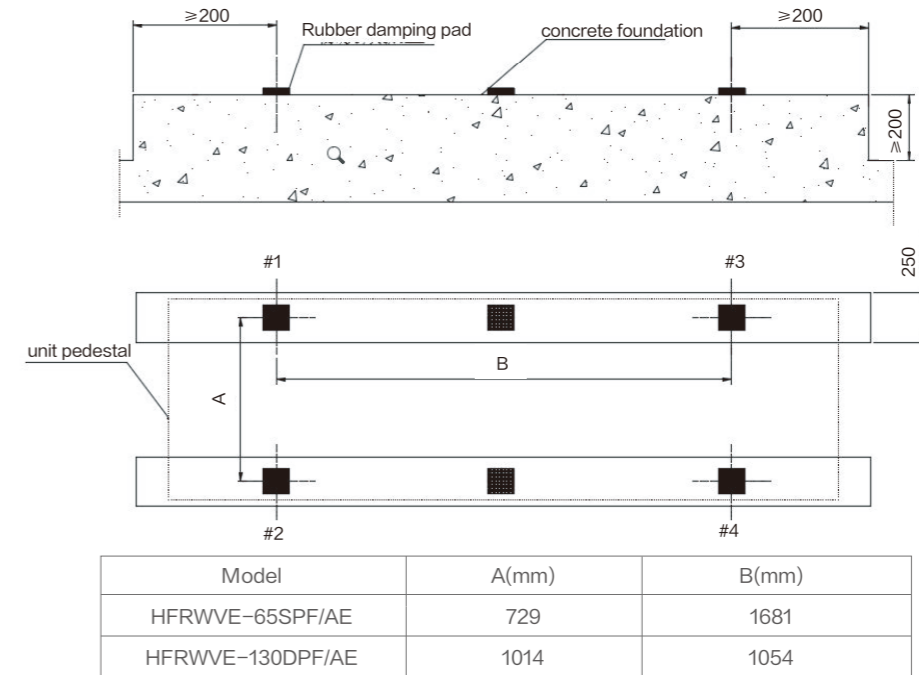

- The foundation must be horizontal, because the inclination will cause incomplete drainage of heat exchanger, and ponding poses a risk of freezing at the ambient temperature below 0°C.
- Drainage ditches shall be provided on both sides of the foundation for drainage.
- The foundation must have adequate bearing capacity.
- When the unit is installed on the building, it is necessary to check the bearing capacity of the building, which shall be completed by the architectural design company.
- If the foundation is made of section steel, it must ensure that the unit and the base are fixed firmly to prevent the unit from displacing due to long-term running vibration.
- The type selection of vibration absorption equipment shall be determined according to the operating weight of the unit.

// Schematic Diagram of Combination

The maximum number of module combination is 16 sets, and one wired remote controller can control a module combination with no more than 16 modules. The main unit and sub-unit are not distinguished in design, using the DIP switch on the main control board to set the main unit and sub-unit. The wired remote controller is connected to the main unit, and the units are connected to each other with communication lines. The arrangement mode of the unit can be determined by users according to the site situation, but the arrangement space of the unit must meet the spacing requirements described in Section of Installation space and enough space shall be reserved for electric cabinet operation and unit maintenance. Different models from the same series can be combined together in control, but it is not recommended. Because the water side resistances of these units are not exactly the same, it is necessary to make the water flow of each unit meet the requirements by adjusting the valve. If the water flow deviation is big, it will activate fault alarm which in turn affects normal use.

HFRWVE-65SPF/AE

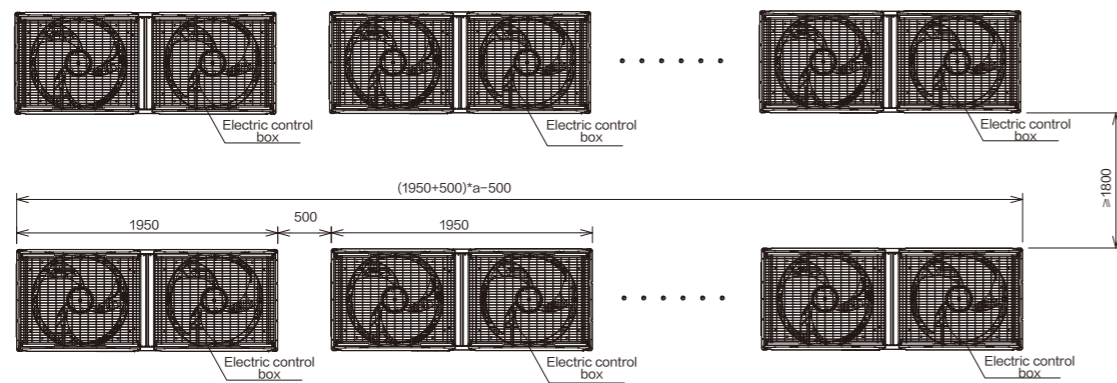

HFRWVE-130DPF/AE

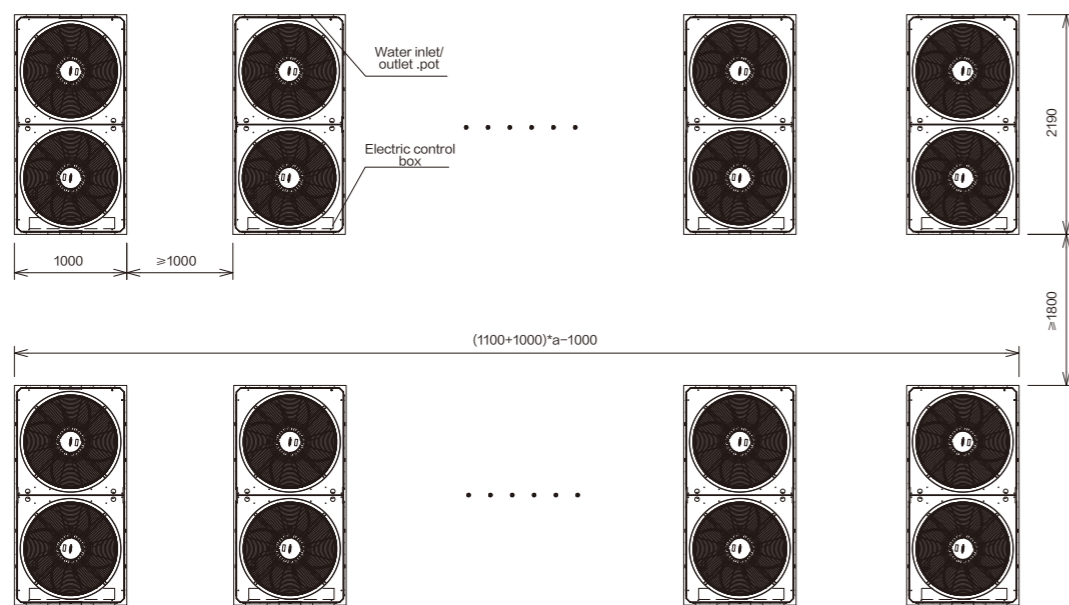

// Electrical Wiring Diagram

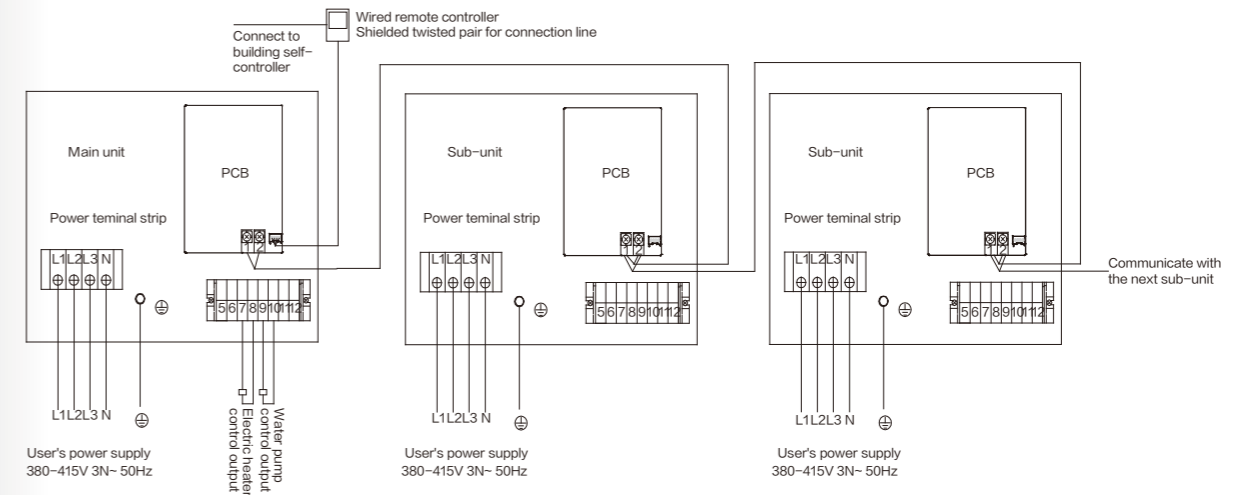

The communication line between modules must use shielded twisted pair and the shielding layer is single-end grounded. It is recommended that the line diameter shall not be less than 0.75mm², and it is forbidden to lay with strong electric lines.

A 30m communication cable should be laid between the wired remote controller and the main unit, and if necessary, it can be lengthened, but the total length shall not exceed 60m. When lengthening the cable, take note that the joints shall be in good contact and sealed well to prevent from the ingress of water.

// Water System Installation

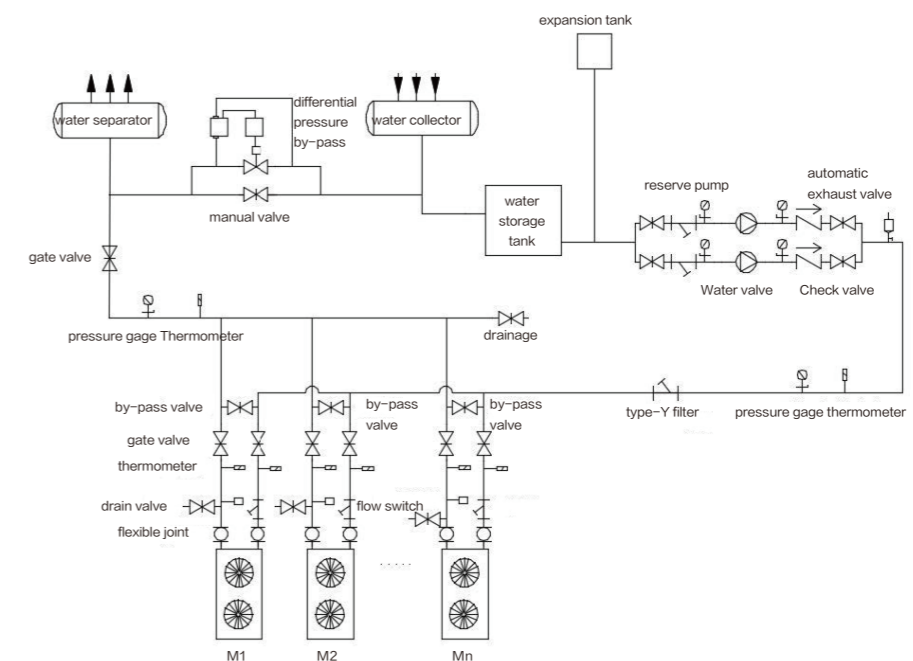

The above figure shows the common connection of water system, symbolically showing the main accessories needed in the water system. The actual installation of the unit shall be subject to the construction drawing provided by the design institute.