



PROCESS COOLING
SOLUTIONS

TAE^{evn} TECH

Air cooled industrial chillers with Scroll compressors and R410A refrigerant
Cooling capacity 7 – 166 kW



*Cooling your industry,
optimising your process.*



Cooling, conditioning, purifying.



TAE^{ev}in TECH

Fruit of 30 years in the industrial chilling market, with thousands of refrigerating machines installed worldwide, TAEvo Tech has been designed specifically for industry. Two new versions, the HE high efficiency and the dual-frequency, integrate the already wide technical equipment of the standard unit, well suited to guarantee a secure and repeatable production process, while saving you money and protecting the environment. Total process security at high efficiency levels makes the TAEvo Tech chiller the optimum solution.



Higher energy efficiency

Thanks especially to the energy efficient scroll compressors, the oversized evaporator and the refrigerant R410A, TAEvo Tech achieves leading energy efficiency levels. This is mated to low maintenance needs, ensuring TAEvo is a highly economical long-term proposition.

Respect of Environment

The eco-friendly refrigerant R410A (ODP=0) with outstanding heat conductivity, coupled with the low absorbed power level of the scroll compressors, reduce the environment impact, minimizing the energy waste. Recyclable and high quality materials ensure respect of environment, and reduces the carbon footprint.

IC208CX microprocessor control

TAEvo Tech features a new advanced microprocessor control technology, with all models fitted with a unique IC208CX digital control. A comprehensive digital display keeps the user fully informed concerning the correct operation of the unit, warnings and alarms.

User friendly

The operation principle of the unit is displayed in a simple and intuitive synoptic sticker with new design. The meaning of the codes of the main alarms shown on the display of the controller, are therefore easy understandable even without the help of the instruction manual, thus facilitating the maintenance activities.

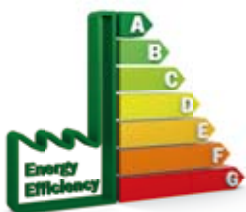

R410A

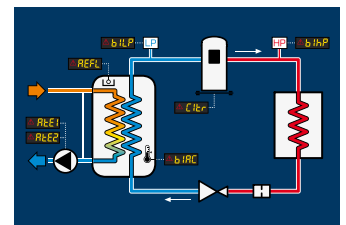

MAXIMUM RELIABILITY, SYSTEM SIMPLIFICATION, ENERGY EFFICIENCY, EXTENSIVE RANGE OF ACCESSORIES AND KITS: THESE ARE SOME OF THE ADVANTAGES OF MTA CHILLERS

Standard features

- Refrigerant R410A;
- Hermetic Scroll compressors;
- High-efficiency finned coil evaporator with copper tubes and aluminum fins, installed inside the water storage tank;
- Axial fans with galvanized steel (mod. 015-020) or die-cast aluminum/plastic crescent-shaped blades (mod. 031-602);
- Air-cooled condensers (copper tubes/aluminium fins) fitted on one side of the chiller. Air filter standard from mod. 031;
- Storage tank (design pressure 6 barg) complete with P3 pump, filling/drain valve, pressure gauge;
- Internal hydraulic bypass between the inlet and outlet connections;
- Electronic level sensor with water conductivity function;
- High and low refrigerant pressure switches;
- Refrigerant pressure gauges (mod. 031-602);
- Parametric microprocessor control IC208CX;
- Protection rating: IP54 (mod. 031-602) or IP44 (mod. 015-020);
- Phase monitor against phase loss and phase reversal;
- Compressor crankcase heater.

Main benefits

- Refrigerant R410A is an environmentally friendly fluid (zero ozone depletion potential) and provides high performances thanks its outstanding heat conductivity;
- The innovative evaporator-in-tank configuration has been designed specifically for industrial process cooling. It allows a reliable operation also with high flow rates (with low pressure drops) and is furthermore compatible with the presence of contaminated process fluids;
- Large cold water tank keeps outlet water temperature constant even under varying load conditions;
- Scroll compressors ensure high efficiency, excellent performance and elevated energy savings;
- Plug-in solution with integrated pump and tank, perfectly suited to the needs of the industrial User;
- Protection class IP54 /IP44 makes TAEvo Tech suitable for outdoor installation;
- Extended operating limits: TAEvo Tech standardly accepts water inlet temperatures up to 35 °C, and delivers outlet temperatures down to -10 °C. TAEvo Tech operates with ambient temperatures up to 46 °C and with minimum ambient temperature down to -5 °C;
- Extensive range of accessories and kits, allow each unit to match the specific customer requirements;
- Cooling circuit suitable both for atmospheric and pressurized hydraulic circuits (up to 6 barg);
- Comprehensive safety equipment, including phase monitor pressure switches, antifreeze sensors, level sensors, crankcase heaters and an internal hydraulic bypass circuit.



The perfect solution, whatever your application

Plastics & rubber: presses, injection moulding, extrusion (sheet & profile), blow moulding, thermoforming, PET.

Lasers, with a specific Laser chiller: cutting, welding, profiling, optics, medical, engraving.

Food & drinks: confectionary, bakeries, distilleries, breweries, wineries, dairies, bottling, carbonation, meat & fish processing, vegetable & salad processing, storage.

Chemical & pharmaceutical: jacketed vessels, polyurethane foam mixers, natural gas, industrial cleaning, laboratories, healthcare, solvents, paints.

Metal working: processing & transformation of precious metals, aluminium working & processing.

Mechanical & Engineering: machine tools, welding machines, rolling mills, presses, extruders, cutting, profiling, polishing, electric spark machinery, hydraulic control unit oil cooling, pneumatic transport, heat treatment.

Paper & related applications: printers, cardboard, labels, plastic film.

Other applications: ceramics, textiles, wood, rental, air compressor cooling, other applications.



Automotive



Food & Beverage



Chemical & Pharmaceutical



Plastics



Laser



Machine Tools



Wineries



Rental

Personalize TAEvo Tech to your individual needs

Main options and kits

The high quality of the standard unit, the wide range of options and kits suitable to develop customized solutions, make TAEvo Tech chillers the ideal choice for every type of industrial cooling application.

- Pump options: P3, P5, double P3+P3 or P5+P5 (mod. 201-602); SP (this version without pump includes the electrical devices necessary to supply an external P3 pump);
- Condenser option: version with painted fins against corrosion;
- Axial fans electronic fan speed control by phase cut (mod. 031-602);
- Centrifugal fans (mod. 031-161);
- High efficiency EC brushless axial fans with high head pressure (max 150 Pa) and inverter control (mod. 201-602);
- Anti-freezing heaters (on tank and pumps) option;
- Soft starter option: factory fitted (mod. 402-602);
- Manual filling tank kit: suitable for hydraulic circuits at atmospheric pressure (mod. 015-602);
- Automatic filling kit: suitable for pressurized hydraulic circuits (up to 6 barg);
- Glycol filling kit: suitable for pressurized hydraulic circuits;
- Automatic glycol pumping group;
- Centrifugal fans kit (mod. 031-161);
- Axial fans electronic fan speed control kit (mod. 031-602);
- Simple remote ON/OFF kit (max 150 m);
- Remote control kit: VICX620 display LED, VGI890 display LCD semi graphic (max 150 m);
- Supervisor kits: RS485 ModBus, xWEB300D.



Internal pump



Centrifugal fans



xWEB300D

Versions

- Non Ferrous Version (mod. 015-351): stainless steel water tank, copper/brass exchanger, stainless steel pump;
- Version for low environmental temperature -20 °C (mod. 031-602): electrical panel heating, electronic fan speed control;
- Dual frequency version (mod. 015-161): 400V/3/50 Hz – 460V/3/60 Hz power supply;
- 60 Hz version (mod. 015-602): 460V/3/60 Hz power supply; electrical panel certified in compliance with UL508A.

Main configurations

TAEvo Tech 50 Hz standard version (Mod. 015-602)

The most popular solution, featuring advanced technical solutions as scroll compressors, a new electronic control, that allow quick and easy installation and high versatility in a multitude of applications. As per the rest of the range, the internal tank and pump offer a fully packaged all-in-one solution.

TAEvo Tech HE High efficiency (Mod. 031-502)

Models TAEvo Tech 031-502 are also available in high efficiency version with class A Eurovent (EN14511). The main features for the HE version are: oversized condensing coils, scroll compressors and high efficiency EC brushless axial fans inverter controlled.

TAEvo Tech dual-frequency (Mod. 015-161)

Dual-frequency units (mod. 015-161) can be supplied indifferently in 400V/3ph/50 Hz - 460V/3ph/60 Hz. This version is available with the following options: P3 pump or SP without pump. This configuration is supplied with axial fans (ON/OFF control).

TAEvo Tech 60 Hz (Mod. 015-602)

Models TAEvo Tech 015-602 are also available in configuration 460V/3/60 Hz with UL certification of the electrical panel suitable for American-Canadian markets. This version features an electrical panel certified in compliance with UL508A, compressors and fans UL compliant.

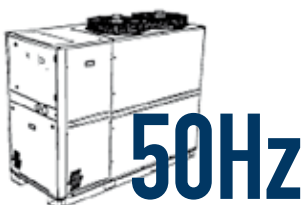

Built to perform

High-efficiency evaporator

High-efficiency finned coil exchanger features copper pipes and aluminum fins, shoulders and cabinet made of galvanized steel. The evaporator is installed inside the water storage tank ensuring reduced ambient heat gain and a steady temperature of the process fluid. The process fluid flows in contact with the finned surface, cooled by the refrigerant which evaporates inside the tubes. This particular technical solution allows TAEvo Tech to operate with high flow rates and reduced pressure drops, ensuring a high level of reliability in heavy industrial applications and also with liquids containing impurities. The heat exchanger is protected from the risk of freezing by a temperature sensor and a control level, by means of which the controller is able to turn the compressors off in case of fault.

Pumps

Centrifugal pumps with seals made of silicon carbide (SiC/SiC/EPDM), available in two different configurations:

Pump P3 - nominal head pressure 3 bar, stainless steel water side mod. 015-251; cast iron mod. 301-602.

Pump P5 - nominal head pressure 5 bar, in stainless steel water side mod. 015-161; cast iron mod. 201-602.

For models 201-602 it is also available the configuration with double pump P3+P3 or P5+P5 in standby, with automatic switching.

Scroll compressors

Compressors with orbiting scrolls, with 2-pole electric motor, mounted on rubber antivibration dampers and complete with protection against overheating, excessive currents and against high temperature of the exhaust gases. Thanks to the axial/radial compliance, the low weight of the rotating components and the absence of suction and discharge valves, they offer a series of benefits as a reduced energy consumptions, low vibrations, less moving parts and high resistance to liquid refrigerant returns.

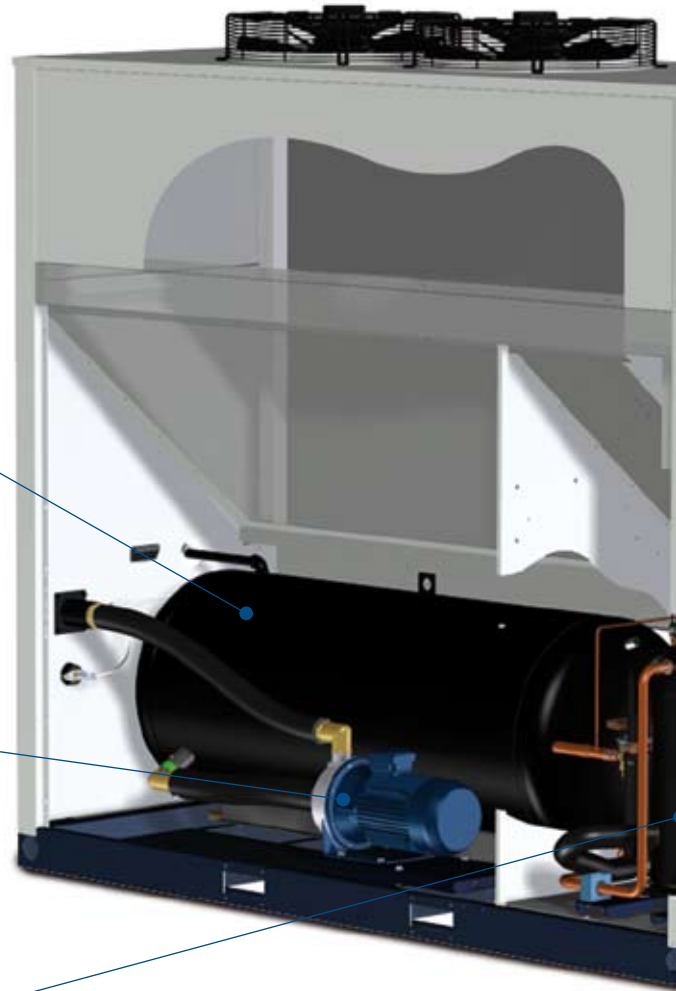

Atmospheric pressure fill kit

This kit is simply installed onto the back of the chiller itself, and features a generous tank with an easy to read water level indication encased within a tough painted steel cabinet. A tap offers easy chiller water tank filling (atmospheric hydraulic circuits).



Pressurised fill kit

This kit, is suitable for pressurised hydraulic circuits (up to 6 barg). The pressurised fill kit features all components required for safe and easy operation, including a pressure reducer, water inlet valve, pressure gauge, automatic relief valve, safety valve and expansion tank.



Remote control options

The following kits allow the remote control of the unit:

- Simple remote control module (ON/OFF, unit status) for installation at up to 150m from unit;
- Advanced remote control kits VICX620 and VISOGRAPH VGI890, both with LED display (full control), for installation at up to 150 m.



Supervisor options

TAEvo Tech can be linked to various external Supervisor systems:

- RS485 serial connection to an external Supervisor system (MODBUS and other leading systems);
- xWEB300D Supervisor kit, operating via Internet;
- xWEB300D + GPRS modem for remote GSM connection directly to a smartphone.





Electric panel

The control section is electrically isolated from the power section through a transformer. The power section is fitted with an interlocked door main switch to prevent access while power supply is on. Electrical equipment is compliant with EN 60204-1 and electrical panel protection degree IP54 compliant with EN 60529. The chiller is tested for electromagnetic compatibility in accordance with applicable EMC standards. A phase monitor standard provides protection against phase loss and phase reversal.

Condensing section

The air-cooled condenser (copper tubes/aluminum fins) is fitted on one side only, reducing space requirements. It has a high working efficiency at high ambient temperatures (+46 °C). A condenser alluminium cleanable air filter is standard from model 031.

Structure

Heavy duty structure with galvanized carbon steel panels protected by an epoxy polyester power coating RAL 7035 (base RAL 5013). Thanks to the configuration of the base, the handling of the unit is easy and secure with a forklift (mod. 015-351) or by lifting bars (mod. 402-602).

Multiple components

Units with 2 compressors (mod. 201 - 351) ensure a precise step control of the cooling capacity. Models 402-602 are equipped with 4 compressors within 2 circuits, they guarantee maximum efficiency both at full and partial load, featuring compressor rotation and unloading function.

Assured quality

EC brushless axial fans (option)

The innovative EC axial fans with high head pressure (max 150 Pa) are operated by a synchronous electric motor with permanent magnets and Integrated inverter speed control. Thanks to the brushless technology these fans feature a reduction in electrical consumption and an increase of reliability and energy efficiency.



Certified performance

All TAEvo Tech, as well as the full range of MTA air-cooled chiller up to 600 kW are certified by Eurovent. MTA has obtained the Eurovent certification, adhering to the LCP program and becoming one of the few companies operating in the industrial sector able to boast this important achievement. A choice fully in line with MTA guiding value, that is the search for reliability and innovation pursued with expertise as well as social and environmental responsibility.



Factory test

All models are individually tested in order to check correct operation, and also undergo refrigerant charge and leakage controls, and micro-processor and safety device setting verifications. Leading brand components are used throughout, ensuring long term reliability.



Technical data

TAEvo Tech 50 Hz

Cooling capacity (1)
Total absorbed power (1)
Cooling capacity (2)
Total absorbed power (2)

TAEvo Tech Dual-frequency - 60 Hz

Cooling capacity (1)
Total absorbed power (1)
Cooling capacity (2)
Total absorbed power (2)

General data

Refrigerant
Protection class
Total installed power 50 Hz (3)
Total installed power 50 Hz / 60 Hz (3)
Cooling circuits / Compressors for circuit
Capacity control

Electrical power supply (3)

Power

Axial fans

Fans number
Total airflow
Power (each) 50 Hz
Power (each) 50 Hz / 60 Hz

Centrifugal fans/high pressure axials fans

Fans number
Total airflow
Available head pressure
Power (each)

Hydraulic group

Water flow rate P3 (min/max)
Available pump head pressure P3
Nominal power P3
Water flow rate P5 (min/max)
Available pump head pressure P5
Nominal power P5

Water flow rate P3 (min/max)
Available pump head pressure P3 (50 Hz)
Available pump head pressure P3 (60 Hz)
Nominal power P3

Tank volume
Max pressure
Water connections

Sound levels (3) (4) - 50 Hz

Sound pressure with axial fans
Sound pressure with centr.fans /high pressure axial fans

Dimensions and installed weight (5)

Width
Length
Height
Weight without pump
Weight with P3
Weight with P5

- (1) Evaporator water inlet/outlet temperature
 - (2) Evaporator water inlet/outlet temperature
 - (3) Unit with P3 pump and ON/OFF control;
 - (4) Sound pressure level in free field at 10m f
 - (5) For units with standard power supply, axial
- Max external air temperature 46 °C (with water)
Data declared according to UNI EN 14511:20

The capacity correction factors in the following selection at conditions differing from the above

Evaporator $\Delta T \neq 5 \text{ }^\circ\text{C}$	$^\circ\text{C}$
Correction factor	K2

Ethylene glycol solutions	%
Correction factor - Cooling capacity	K4

	015	020	031	051	081	101	121	161	201	251	301	351	402	502	602	
kW	7,00	8,30	13,3	19,4	30,1	39,2	48,3	55,5	64,1	75,7	84,1	96,2	123,2	146,4	166,1	
kW	1,95	1,77	3,08	4,29	7,31	8,40	10,6	13,6	14,7	18,1	19,1	23,7	29,4	33,6	38,8	
kW	5,00	5,96	9,58	13,9	22,3	29,1	35,9	41,5	47,5	55,6	62,0	71,7	91,3	107,7	122,4	
kW	2,16	2,19	3,52	4,95	8,18	9,60	12,0	14,9	16,7	20,6	21,7	26,4	33,3	38,5	44,0	
kW	8,48	9,98	15,9	22,7	35,4	45,7	55,9	64,2	-	-	-	-	-	-	-	
kW	2,38	2,17	3,77	5,41	8,98	10,6	13,3	17,0	-	-	-	-	-	-	-	
kW	6,08	7,19	11,5	16,3	26,2	33,9	41,7	48,1	-	-	-	-	-	-	-	
kW	2,64	2,66	4,29	6,19	10,1	12,0	15,0	18,5	-	-	-	-	-	-	-	
R410A																
	IP 44				IP54											
kW	3,8	3,9	5,7	7,4	12,0	14,4	18,3	20,5	23,7	27,0	31,1	36,3	48,9	55,5	61,4	
kW	4,0 / 5,2	4,1 / 5,4	5,6 / 7,4	7,3 / 9,3	12,5 / 15,4	14,9 / 18,3	17,8 / 22,6	20,1 / 25,3	-	-	-	-	-	-	-	
N°	1 / 1	1 / 1	1 / 1	1 / 1	1 / 1	1 / 1	1 / 1	1 / 1	1 / 2	1 / 2	1 / 2	2 / 2	2 / 2	2 / 2	2 / 2	
%	0-100	0-100	0-100	0-100	0-100	0-100	0-100	0-100	0-50-100	0-50-100	0-50-100	0-50-100	0-25-50-75-100	0-25-50-75-100	0-25-50-75-100	
V/Ph/Hz	400 ± 10% / 3 - PE / 50 - (460 ± 10% / 3 - PE / 60 dual-frequency version)								400 ± 10% / 3 - PE / 50							
N°	1	1	1	1	1	2	2	2	2	2	3	3	2	2	2	
m³/h	3500	3150	6500	6150	8150	14200	13600	13600	16200	16000	22200	21600	45800	44400	42800	
kW	0,203	0,203	0,48	0,48	0,71	0,71	0,71	0,71	0,71	0,71	0,71	0,71	2,1	2,1	2,1	
kW	0,29/0,45	0,29/0,45	0,48/0,76	0,48/0,76	0,69/1,03	0,69/1,03	0,69/1,03	0,69/1,03	-	-	-	-	-	-	-	
N°	-	-	1	1	2	2	2	2	2	2	3	3	2	2	2	
m³/h	-	-	6600	6000	9200	12800	12800	12800	14600	14600	20100	20100	40000	40000	40000	
Pa	-	-	159	188	265	134	115	115	151	144	150	142	198	185	172	
kW	-	-	1,1	1,1	1,1	1,1	1,1	1,1	0,9	0,9	0,9	0,9	2,8	2,8	2,8	
m³/h	0,4/4,8	0,4/4,8	0,7/6	0,9/6	1,9/9,1	2,1/9,3	2,6/18	3,2/18	3,4/18	3,4/18	4,8/27	5,6/27	6,6/48	8,1/48	9,4/48	
barg	3,0/1,4	3,0/1,4	3,1/1,6	3,0/1,5	3,0/1,5	2,9/1,6	2,8/1,7	2,8/1,7	2,8/2,1	2,8/2,1	3,3/0,9	3,3/0,9	3,9/1,5	3,8/1,5	3,8/1,5	
kW	0,55	0,55	0,75	0,75	0,9	0,9	1,85	1,85	1,85	1,85	2,2	2,2	4	4	4	
m³/h	0,4/4,8	0,4/4,8	0,7/4,3	0,9/4,5	1,9/12,6	2,1/12,6	2,6/12,6	3,2/12,6	3,4/27	3,4/27	4,8/27	5,6/27	6,6/48	8,1/48	9,4/48	
barg	5,4/3,0	5,4/3,0	5,3/3,7	5,2/3,5	5,2/3,2	5,2/3,6	5,2/3,6	5,1/3,7	5,2/2,4	5,2/2,4	5,1/2,4	5,1/2,4	5,5/3,1	5,5/3,1	5,5/3,1	
kW	1,1	1,1	1,1	1,1	2,2	2,2	2,2	2,2	4	4	4	4	7,5	7,5	7,5	
m³/h	0,4/4,8	0,4/4,8	0,4/4,8	0,4/4,8	2,3/9,0	2,3/9,0	3,5/16,2	3,5/16,2	-	-	-	-	-	-	-	
barg	3,1/2,0	3,1/2,0	3,1/2,0	3,1/2,0	3,1/1,9	3,1/1,9	2,4/2,0	2,4/2,0	-	-	-	-	-	-	-	
barg	4,4/2,8	4,4/2,8	4,4/2,8	4,4/2,8	4,3/2,9	4,3/2,9	3,4/2,5	3,4/2,5	-	-	-	-	-	-	-	
kW	1,1	1,1	1,1	1,1	2,2	2,2	2,2	2,2	-	-	-	-	-	-	-	
l	60	60	115	115	140	255	255	255	350	350	350	350	500	500	500	
barg	6	6	6	6	6	6	6	6	6	6	6	6	6	6	6	
Rp	3/4"	3/4"	1"	1"	1 1/2"	1 1/2"	1 1/2"	1 1/2"	2"	2"	2"	2"	2 1/2"	2 1/2"	2 1/2"	
dB [A]	52,4	52,4	53,1	53,1	53,6	54,1	54,1	55,0	56,3	56,3	58,0	58,0	61,5	61,5	61,5	
dB [A]	-	-	58,8	58,8	61,2	61,2	61,2	61,2	57,0	57,0	58,7	58,7	63,1	63,1	63,1	
mm	560	560	660	660	760	760	760	760	865	865	865	865	1255	1255	1255	
mm	1265	1265	1310	1310	1865	1865	1865	1865	2255	2255	2255	2255	3295	3295	3295	
mm	794	794	1400	1400	1447	1447	1447	1447	2065	2065	2065	2065	2159	2159	2159	
kg	194	198	320	339	451	613	626	650	957	1018	999	1020	1654	1703	1730	
kg	206	210	333	351	464	626	643	667	974	1035	1038	1059	1701	1750	1777	
kg	212	216	337	356	477	639	652	676	1011	1072	1053	1074	1733	1782	1809	

20/15 °C, external air temperature 25 °C;
12/7 °C, external air temperature 35 °C;

from unit condenser side and 1,6 m from ground;
all fans, ON/OFF fan speed control.
water temperature 12/7 °C).

11.

ing table should be used as a guide only, for accurate
the selection software should be utilised.

4	5	6	7	8	9	10
0,994	1	1,005	1,010	1,017	1,021	1,025

0	10	20	30	40	50
1	0,99	0,98	0,97	0,96	0,93

Typical configuration for users suitable for closed circuits

The below diagram shows a typical closed circuit lay-out. Pressurised closed circuit applications (5) always require an expansion vessel. TAEvo Tech units in standard (evaporator in tank) configurations are ideal for such applications, and offer a pressurised automatic fill kit including the expansion tank (as option). Pressurised closed circuit applications (5) can also feature TAEvo Tech units equipped with prismatic tank and plate type evaporator, with these featuring a pump and a tank kit (verify the height difference between the chiller and the user).

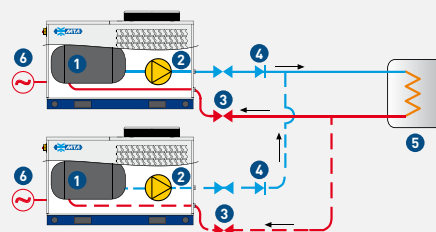

- 1 Accumulation tank
- 2 Pump
- 3 Valve
- 4 Non return valve
- 5 User
- 6 Expansion tank

Typical configuration for users suitable for open circuit

The below diagram shows a typical open circuit lay-out. For atmospheric circuit applications featuring an open tank (4), the water is in contact with the ambient air, as such no expansion vessel is required. Such applications are suited to TAEvo Tech units in standard (evaporator in tank) configuration but without the tank kit and pump, given that the system typically features an external pump (2).

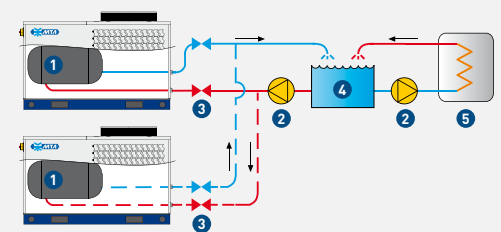

- 1 Accumulation tank
- 2 Pump
- 3 Valve
- 4 Non return valve
- 5 Open tank



www.mta-it.com



M.T.A. S.p.A.

Viale Spagna, 8 ZI
35020 Tribano (PD) Italy

Tel. +39 049 9588611
Fax +39 049 9588676

info@mta-it.com
www.mta-it.com

Milan branch office

Tel. +39 02 95738492

MTA France S.A.

Tel: +33 04 7249 8989
www.mtafrance.fr

MTA Deutschland GmbH

Tel: +49 (2157) 12402 - 0
www.mta.de

Novair-MTA, S.A. (España)

Tel: +34 938 281 790
www.novair-mta.com

SC MTA ROMÂNIA Srl

Tel: +40 723 022023
www.mta-it.ro

MTA USA, LLC

Tel: +1 716 693 8651
www.mta-usa.com

MTA Australasia Pty Ltd

Tel: +61 1300 304 177
www.mta-au.com

MTA is represented in over 80 countries worldwide. For information concerning your nearest MTA representative please contact M.T.A. S.p.A.

The continuous improvement of MTA's products can cause some variations in the information herein even without prior notice. Reproduction in whole or in part is forbidden.



MTA is ISO9001 certified, a sign of its commitment to complete customer satisfaction.



MTA products comply with European safety directives, as recognised by the CE symbol.



MTA participates in the E.C.C. programme for LCP-HP. Certified products are listed on www.eurovent-certification.com Eurovent Certification applied to the units:
- Air/Water with cooling capacity up to 600 kW
- Water/Water up to 1500 kW



GOST Certification



Cooling, conditioning, purifying.